

Pressure reducers

Art. 9017



100% MADE IN ITALY 

Function Pintossi+C pressure reducers with piston and clearing house have the function **to reduce and stabilize fluids pressure** in a distribution system, in accordance with the set value. This product is particularly indicated to avoid damages on system components when pressure gets to high levels.

The specific strenght properties of the internal components used in the pressure reducers allow to use it in systems where the pressure values from the public water supply can reach very high value, **up to 40bar**.

The setting of the outlet pressure is very precise thanks to the internal components' materials, granting low head losses. This model can be used in domestic systems, conditioning systems, irrigation systems, sanitary systems, compressed air systems, etc.

The pressure reducer is certified to be used with drinking water and made in accordance with Italian D.M. 174/2004.

Technical specifications

Fluids:	Water or glycol solutions and air
Max glycol:	30%
Max. working temperature:	80°C
Max working pressure:	25 bar
Max upstream pressure:	40 bar
Pre-setting:	3 bar
Outlet setting range:	1 - 9 bar
Manometer connections:	1/4"

Materials

Body:	Brass CW617N
Screw:	Brass CW617N
Gaskets:	NBR
Seat:	Stainless steel
Stem:	Stainless steel

Dimensions

Ø	DN	H	L	L1
1/2"	15	143	112	75
3/4"	20	174	135	88
1"	25	180	140	93
1 ¼"	32	220	170	110
1 ½"	40	220	175	112
2"	50	250	200	130

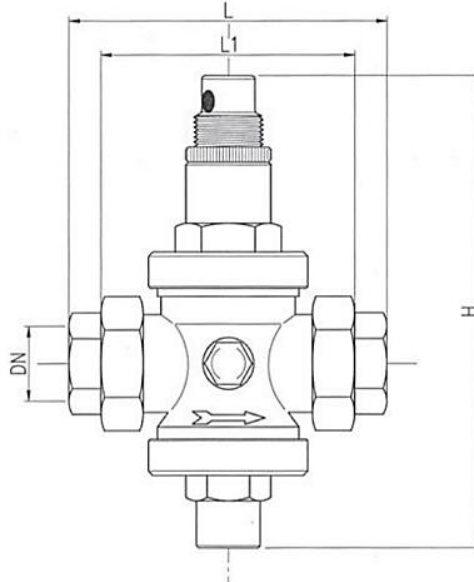

Installation

Pintossi+C pressure reducers can be installed in every position.

Before making the installation, it's important to clean the system and discharge it from air that could be present inside. To grant a correct functioning and make easier maintenance operations is highly recommended to install it together with the following products:

- A **self-cleaning filter** in the different model available (art.9060-9065) or a **Y filter** (art.9023) upstream, in order to grant the cleaning of the inlet fluid that otherwise could damage internal pressure reducer components;
- A **shut-off valve** (art. 5130) upstream and downstream, in order to be able to isolate the pressure reducers during ordinary and extraordinary maintenance;
- A **water-hammer absorber** (art.9019) downstream, to avoid that unexpected pressure increases could damage the system components;
- An **expansion vessel** in system where are present hot water heaters or hot water storage. The vessel should be installed between the pressure reducers and the boiler.

Pressure setting

Pintossi+C pressure reducers are 100% tested and pre-set to outlet standard pressure of 3 bar. In any case the outlet pressure can be easily changed inside the outlet pressure setting range.

To modify this value follow next steps:

1. Loose the ring which push on the spring to remove tense on the spring itself;
2. Turn clockwise to increase the outlet pressure;
3. Turn anti-clockwise to reduce outlet pressure.

The correct pressure setting should be done when the system is closed.



Head loss

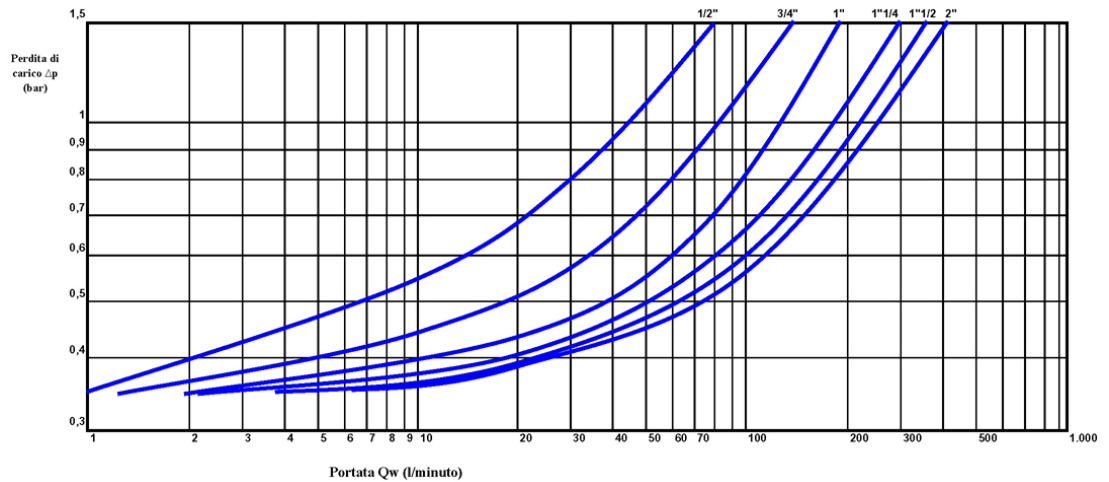

Cavitation phenomenon

To limit as much as possible cavitation phenomenon, that could make problems in pressure reducers functioning, like noise and sealing problems, is highly recommended to maintain the upstream and downstream pressure ratio between the values shown in the graph below:

DIAGRAMMA DI CAVITAZIONE:

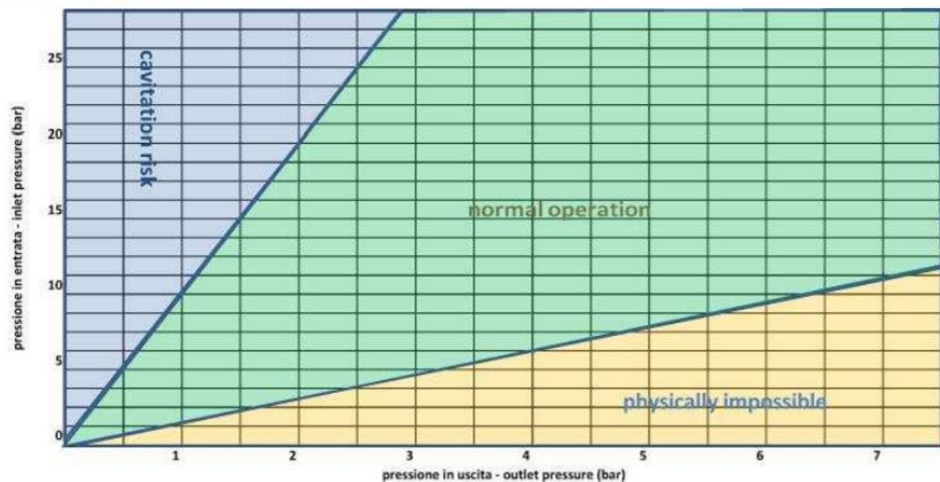

Calculation example: upstream pressure 8 bar, downstream pressure 4 bar, pressure ratio 2:1.

Thanks to the specific design and the use of very resistant materials for internal components, such as stainless steel, Pintossi+C pressure reducers are particularly efficient, being able to work in standard conditions with **pressure ratio 5:1**. Cavitation phenomenon evaluations, in addition to the above indications, must take into consideration even other factors that can affect it directly, like system fluid temperature, air presence, etc.

In the situation where it could be necessary, for the specific type of installation, exceed this value, is recommended to use more pressure reducers in line, in order to split the pressure ratio on more products

Fluid characteristics

Reference standard for water treatments in heating systems is Norm UNI 8065:2019 which regulates the parameters that must be observed to avoid scale and corrosion phenomena.

In order to grant product warranty, the fluid characteristics must comply with the rules in force in the country of relevance or at least present features not less to the ones prescribed by the Norm UNI 8065:2019.

In particular, minimum standards necessary but not sufficient to control are the following:

Fluid aspect: Limpid

PH: Between 7 and 8

Iron (FE): < 0,5 mg/kg (< 0,1 mg/kg for steam)

Copper (CU): < 0,1 mg/kg (< 0,05 mg/kg for steam)

Antifreeze: Passivated Propylene Glycol

Conditioning: as indicated by the producer

In any case when using antifreeze and conditioning solutions, is required to control and verify the correct compatibility between these substances and the construction materials stated in Pintossi+C technical datasheet.